



# METEOROLOGICAL INSTRUMENTS

## INSTRUCTIONS

**WIND MONITOR-AQ  
WITH 4-20mA OUTPUTS  
MODEL 05305L**





**MODEL 05305L  
WIND MONITOR-AQ  
with 4-20mA OUTPUTS**



**WIND SPEED SPECIFICATION SUMMARY**

Range	0 to 50 m/s (112 mph)
Sensor	20 cm diameter 4-blade helicoid carbon fiber thermoplastic propeller, 30.7 cm air passage per revolution
Distance Constant	2.1 m (6.9 ft.) for 63% recovery
Threshold Sensitivity	0.4 m/s (0.9 mph)
Transducer	Centrally mounted stationary coil, 2K Ohm nominal DC resistance
Output Signal	4 to 20 mA = 0 to 100 m/s

**WIND DIRECTION (AZIMUTH) SPECIFICATION SUMMARY**

Range	360° mechanical, 355° electrical (5° open)
Sensor	Balanced vane, 48.3 cm (19 in) turning radius.
Damping Ratio	0.45
Delay Distance	1.2 m (3.9 ft) for 50% recovery
Threshold Sensitivity	0.5 m/s (1.0 mph) at 10° displacement
Damped Natural Wavelength	4.9 m (16.1 ft)
Undamped Natural Wavelength	4.4 m (14.4 ft)
Transducer	Precision conductive plastic potentiometer, 10K ohm resistance (±20%), 0.25% linearity, life expectancy 50 million revolutions, rated 1 watt at 40°C, 0 watts at 125°C
Output Signal	4 to 20 mA for 0 to 360°

**GENERAL**

Power Requirement:	12 - 30 VDC
Operating Temp:	-50 to 50°C (-58 to 122°F)

**INTRODUCTION**

The Wind Monitor measures horizontal wind speed and direction. Developed for air quality applications, it is accurate, sensitive, and corrosion resistant. The main housing, nose cone, propeller, and other internal parts are injection molded U.V. stabilized plastic. The tail section is lightweight expanded polystyrene. Both the propeller and vertical shafts use stainless steel precision grade ball bearings. Bearings have shields to help exclude contamination and moisture.

Propeller rotation produces an AC sine wave signal with frequency proportional to wind speed. Internal circuitry converts the raw signal to 4 to 20 mA current output over specified wind speed range.

Vane position is sensed by a 10K ohm precision conductive plastic potentiometer. This signal is also converted to 4 to 20mA output.

The instrument mounts directly on a standard one inch pipe, outside diameter 34 mm (1.34"). An orientation ring is provided so the instrument can be removed for maintenance and re-installed without loss of wind direction reference. Both the sensor and the orientation ring are secured to the mounting pipe by stainless steel band clamps. Electrical connections are made in a junction box at the base.

**INITIAL CHECK-OUT**

When the Wind Monitor is unpacked it should be checked carefully for any signs of shipping damage.

Remove the plastic nut on the propeller shaft. Install the propeller on the shaft with the serial number of the propeller facing forward (into the wind). The instrument is aligned, balanced and fully calibrated before shipment; however, it should be checked both mechanically and electrically before installation. The vane and propeller should easily rotate 360° without friction. Check vane balance by holding the instrument base so the vane surface is horizontal. It should have near neutral torque without any particular tendency to rotate. A slight imbalance will not degrade performance.

**INSTALLATION**

Proper placement of the instrument is very important. Eddies from trees, buildings, or other structures can greatly influence wind speed and wind direction observations. To get meaningful data for most applications, locate the instrument well above or upwind from obstructions. As a general rule, the air flow around a structure is disturbed to twice the height of the structure upwind, six times the height downwind, and up to twice the height of the structure above ground. For some applications it may not be practical or necessary to meet these requirements.

**FAILURE TO PROPERLY GROUND THE WIND MONITOR  
MAY RESULT IN ERRONEOUS SIGNALS  
OR TRANSDUCER DAMAGE.**

Grounding the Wind Monitor is vitally important. Without proper grounding, static electrical charge can build up during certain atmospheric conditions and discharge through the transducers. This discharge may cause erroneous signals or transducer failure. To direct the discharge away from the transducers, the mounting post assembly in which the transducers are mounted is made with a special anti-static plastic. It is important that the mounting post be connected to a good earth ground. There are two ways this may be accomplished. First, the Wind Monitor may be mounted

05305L-90(G)

on a metal pipe which is connected to earth ground. The mounting pipe should not be painted where the Wind Monitor is mounted. Towers or masts set in concrete should be connected to one or more grounding rods. If it is difficult to ground the mounting post in this manner, the following method should be used. Inside the junction box the screw labeled EARTH GND is internally connected to the anti-static mounting post. This terminal should be connected to an earth ground (Refer to wiring diagram).

Initial installation is most easily done with two people; one to adjust the instrument position and the other to observe the indicating device. After initial installation, the instrument can be removed and returned to its mounting without re-aligning the vane since the orientation ring preserves the wind direction reference. Install the Wind Monitor following these steps:

1. MOUNT WIND MONITOR
  - a) Place orientation ring on mounting post. Do Not tighten band clamp yet. Orientation ring may be omitted when portable tripod is used.
  - b) Place Wind Monitor on mounting post. Do Not tighten band clamp yet.
2. CONNECT SENSOR CABLE.
  - a) Refer to wiring diagram located at back of manual.
3. ALIGN VANE
  - a) Connect instrument to indicator.
  - b) Choose a known wind direction reference point on the horizon.
  - c) Sighting down instrument centerline, point nose cone at reference point on horizon.
  - d) While holding vane in position, slowly turn base until indicator shows proper value.
  - e) Tighten mounting post band clamp.
  - f) Engage orientation ring indexing pin in notch at instrument base.
  - g) Tighten orientation ring band clamp.

## **CALIBRATION**

The Wind Monitor is fully calibrated before shipment and should require no adjustments. Recalibration may be necessary after some maintenance operations. Periodic calibration checks are desirable and may be necessary where the instrument is used in programs which require auditing of sensor performance.

Accurate wind direction calibration requires a Model 18112 Vane Angle Bench Stand. Begin by connecting the instrument to a signal conditioning circuit which has some method of indicating the wind direction value. This may be a display which shows wind direction values in angular degrees or simply a voltmeter monitoring the output. Orient the base so the junction box faces due south. Visually align the vane with the crossmarkings and observe the indicator output. If the vane position and indicator do not agree within 5°, it may be necessary to adjust the potentiometer coupling inside the main housing. Details for making this adjustment appear in the MAINTENANCE, POTENTIOMETER REPLACEMENT, outline, step 7.

It is important to note that while the sensor mechanically rotates through 360°, full scale wind direction signal from the signal conditioning occurs at 355°. The signal conditioning electronics must be adjusted accordingly. For example, in a circuit where 4 to 20 mA represents 0° to 360°, the output must be adjusted for 19.8 mA when the instrument is at 355°.  $(((355°/360°) \times 16 \text{ mA}) + 4 \text{ mA})$ .

05305L-90(G)

Wind speed calibration is determined by propeller pitch and the output characteristics of the transducer. Calibration formulas showing wind speed vs. propeller rpm and output frequency are included below. Standard accuracy is ± 0.2 m/s (0.4 mph). For greater accuracy, the sensor must be individually calibrated in comparison with a wind speed standard. Contact the factory or your supplier to schedule a NIST (National Institute of Standards & Technology) traceable wind tunnel calibration in our facility.

To calibrate wind system electronics, temporarily remove the propeller and connect an Anemometer Drive (18802 or equivalent) to the propeller shaft. Apply the calibration formula to the calibrating motor rpm and adjust the electronics for the proper value. For example, with the propeller shaft turning at 3600 rpm, adjust an indicator to display 18.4 m/s  $[3600 \text{ rpm} \times 0.00512 \text{ (m/s)/rpm} = 18.4 \text{ m/s.}]$

Details on checking bearing torque, which affects wind speed and direction threshold, appear in the following section.

## **CALIBRATION FORMULAS**

### **Model 05305L Wind Monitor w/08254 Propeller**

WIND SPEED	vs	PROPELLER RPM
m/s	=	0.00512 x rpm
knots	=	0.00995 x rpm
mph	=	0.01145 x rpm
km/h	=	0.01843 x rpm

WIND SPEED	vs	mA OUTPUT
m/s	=	( 6.250 x mA)-25
knots	=	(12.125 x mA)-48.5
mph	=	(13.980 x mA)-56
km/h	=	(22.500 x mA)-90

WIND DIRECTION	vs	mA OUTPUT
DEGREES	=	(22.5 x mA)-90

## **MAINTENANCE**

Given proper care, the Wind Monitor should provide years of service. The only components likely to need replacement due to normal wear are the precision ball bearings and the wind direction potentiometer. Only a qualified instrument technician should perform the replacement. If service facilities are not available, return the instrument to the company. Refer to the drawings to become familiar with part names and locations. The asterisk \* which appears in the following outlines is a reminder that maximum torque on all set screws is 80 oz-in.

### **POTENTIOMETER REPLACEMENT**

The potentiometer has a life expectancy of fifty million revolutions. As it becomes worn, the element may begin to produce noisy signals or become non-linear. When signal noise or non-linearity becomes unacceptable, replace the potentiometer. Refer to exploded view drawing and proceed as follows:

1. REMOVE MAIN HOUSING
  - a) Unscrew nose cone from main housing. Set o-ring aside for later use.
  - b) Gently push main housing latch.
  - c) While pushing latch, lift main housing up and remove it from vertical shaft bearing rotor.
2. UNSOLDER TRANSDUCER WIRE
  - a) Remove junction box cover, exposing circuit board.
  - b) Remove screws holding circuit board.
  - c) Unsolder three potentiometer wires (white, green, black), two wind speed coil wires (red, black), and earth ground wire (red) from board.

### 3. REMOVE POTENTIOMETER

- a) Loosen set screw on potentiometer coupling and remove it from potentiometer adjust thumbwheel.
- b) Loosen set screw on potentiometer adjust thumbwheel and remove it from potentiometer shaft.
- c) Loosen two set screws at base of transducer assembly and remove assembly from vertical shaft.
- d) Unscrew potentiometer housing from potentiometer mounting & coil assembly.
- e) Push potentiometer out of potentiometer mounting & coil assembly by applying firm but gentle pressure on potentiometer shaft.

### 4. INSTALL NEW POTENTIOMETER

- a) Push new potentiometer into potentiometer mounting & coil assembly.
- b) Feed potentiometer and coil wires through hole in bottom of potentiometer housing.
- c) Screw potentiometer housing onto potentiometer mounting & coil assembly.
- d) Gently pull transducer wires through bottom of potentiometer housing to take up any slack. Apply a small amount of silicone sealant around hole.
- e) Install transducer assembly on vertical shaft allowing 0.5 mm (0.020") clearance from vertical bearing. Tighten set screws\* at bottom of transducer assembly.
- f) Place potentiometer adjust thumbwheel on potentiometer shaft and tighten set screw\*.
- g) Place potentiometer coupling on potentiometer adjust thumbwheel. Do Not tighten set screw yet.

### 5. RECONNECT TRANSDUCER WIRES

- a) Using needle-nose pliers or a paper clip bent to form a small hook, gently pull transducer wires through hole in junction box.
- b) Solder wires to circuit board according to wiring diagram. Observe color code.
- c) Secure circuit board in junction box using two screws removed in step 2b. Do not overtighten.

### 6. REPLACE MAIN HOUSING

- a) Place main housing over vertical shaft bearing rotor. Be careful to align indexing key and channel in these two assemblies.
- b) Place main housing over vertical shaft bearing rotor until potentiometer coupling is near top of main housing.
- c) Turn potentiometer adjust thumbwheel until potentiometer coupling is oriented to engage ridge in top of main housing. Set screw on potentiometer coupling should be facing the front opening.
- d) With potentiometer coupling properly oriented, continue pushing main housing onto vertical shaft bearing rotor until main housing latch locks into position with a "click".

### 7. ALIGN VANE

- a) Connect excitation voltage and signal conditioning electronics to terminal strip according to wiring diagram.
- b) With mounting post held in position so junction box is facing due south, orient vane to a known angular reference. Details appear in CALIBRATION section.
- c) Reach in through front of main housing and turn potentiometer adjust thumbwheel until signal conditioning system indicates proper value.
- d) Tighten set screw\* on potentiometer coupling.

### 8. REPLACE NOSE CONE

- a) Screw nose cone into main housing until o-ring seal is seated. Be certain threads are properly engaged to avoid cross-threading.

## **FLANGE BEARING REPLACEMENT**

---

If anemometer bearings become noisy or wind speed threshold increases above an acceptable level, bearings may need replacement. Check anemometer bearing condition using a Model 18310 Propeller Torque Disc. If necessary, bearings are replaced as follows.

### 1. REMOVE OLD BEARINGS

- a) Unscrew nose cone. Set o-ring aside for later use.
- b) Loosen set screw on magnet shaft collar and remove magnet.
- c) Slide propeller shaft out of nose cone assembly.
- d) Remove front bearing cap which covers front bearing.
- e) Remove both front and rear bearings from nose cone assembly. Insert edge of a pocket knife under bearing flange and lift it out.

### 2. INSTALL NEW BEARINGS

- a) Insert new front and rear bearings into nose cone.
- b) Replace front bearing cap.
- c) Carefully slide propeller shaft thru bearings.
- d) Place magnet on propeller shaft allowing 0.5 mm (0.020") clearance from rear bearing.
- e) Tighten set screw\* on magnet shaft collar.
- f) Screw nose cone into main housing until o-ring seal is seated. Be certain threads are properly engaged to avoid cross-threading.

## **VERTICAL SHAFT BEARING REPLACEMENT**

---

Vertical shaft bearings are much larger than the anemometer bearings. Ordinarily, these bearings will require replacement less frequently than anemometer bearings. Check bearing condition using a Model 18331 Vane Torque Gauge.

Since this procedure is similar to POTENTIOMETER REPLACEMENT, only the major steps are listed here.

### 1. REMOVE MAIN HOUSING.

2. UNSOLDER TRANSDUCER WIRES AND REMOVE TRANSDUCER ASSEMBLY. Loosen set screws at base of transducer assembly and remove entire assembly from vertical shaft.
3. REMOVE VERTICAL SHAFT BEARING ROTOR by sliding it upward off vertical shaft.
4. REMOVE OLD VERTICAL BEARINGS AND INSTALL NEW BEARINGS. When inserting new bearings, be careful not to apply pressure to bearing shields.
5. REPLACE VERTICAL SHAFT BEARING ROTOR.
6. REPLACE TRANSDUCER & RECONNECT WIRES.
7. REPLACE MAIN HOUSING.
8. ALIGN VANE.
9. REPLACE NOSE CONE.

\*Max set screw torque 80 oz-in

## **WARRANTY**

---

This product is warranted to be free of defects in materials and construction for a period of 12 months from date of initial purchase. Liability is limited to repair or replacement of defective item. A copy of the warranty policy may be obtained from R. M. Young Company.

## **CE COMPLIANCE**

---

This product has been tested and shown to comply with European CE requirements for the EMC Directive. Please note that shielded cable must be used.

### **Declaration of Conformity**

R. M. Young Company  
2801 Aero Park Drive  
Traverse City, MI 49686 USA

Model 05305L WIND MONITOR-AQ /W 4-20 mA OUT

The undersigned hereby declares on behalf of R. M. Young Company that the above-referenced product, to which this declaration relates, is in conformity with the provisions of:

Council Directive 2004/108/EC (December 15, 2004)  
on Electromagnetic Compatibility



David Poinsett  
R&D Manager



# CABLE & WIRING DIAGRAM

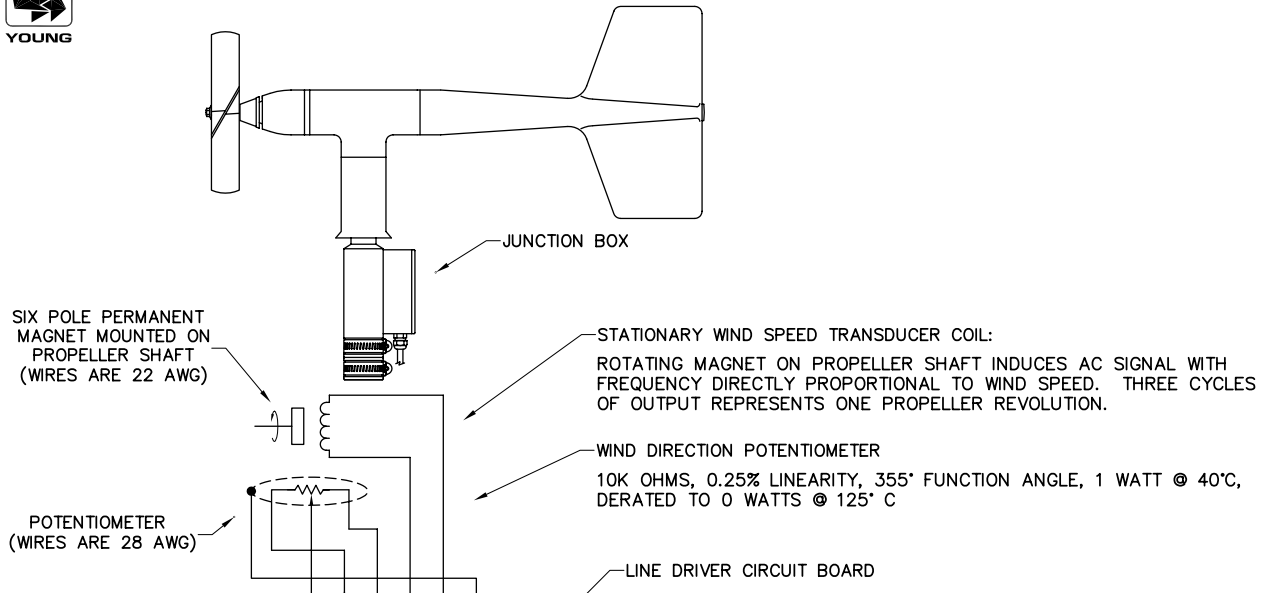

## CALIBRATION FORMULAS

### Model 05305L

WIND SPEED	vs	mA OUTPUT
m/s	=	( 6.250 x mA)-25
knots	=	(12.125 x mA)-48.5
mph	=	(13.980 x mA)-56
km/h	=	(22.500 x mA)-90

WIND DIRECTION	vs	mA OUTPUT
DEGREES	=	(22.5 x mA)-90

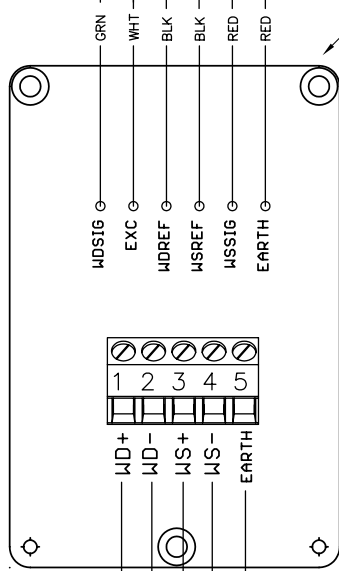

THE EARTH GROUND TERMINAL MUST BE CONNECTED TO EARTH GROUND TO PROVIDE A STATIC DISCHARGE PATH.

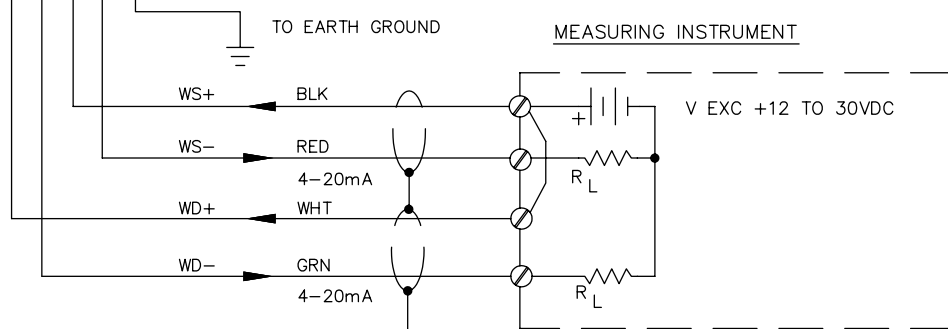

$$\text{MAX LOAD RESISTOR } (R_L) \text{ VALUE} = \frac{V_{\text{EXC}} - 12}{0.02} = R_L$$

$$V \text{ SUPPLY (MIN)} = 0.02 \times R_L + 12 \text{ (} R_L \text{ IS WIRE RESISTANCE)}$$



## BEARING REPLACEMENT & POTENTIOMETER ADJUSTMENT

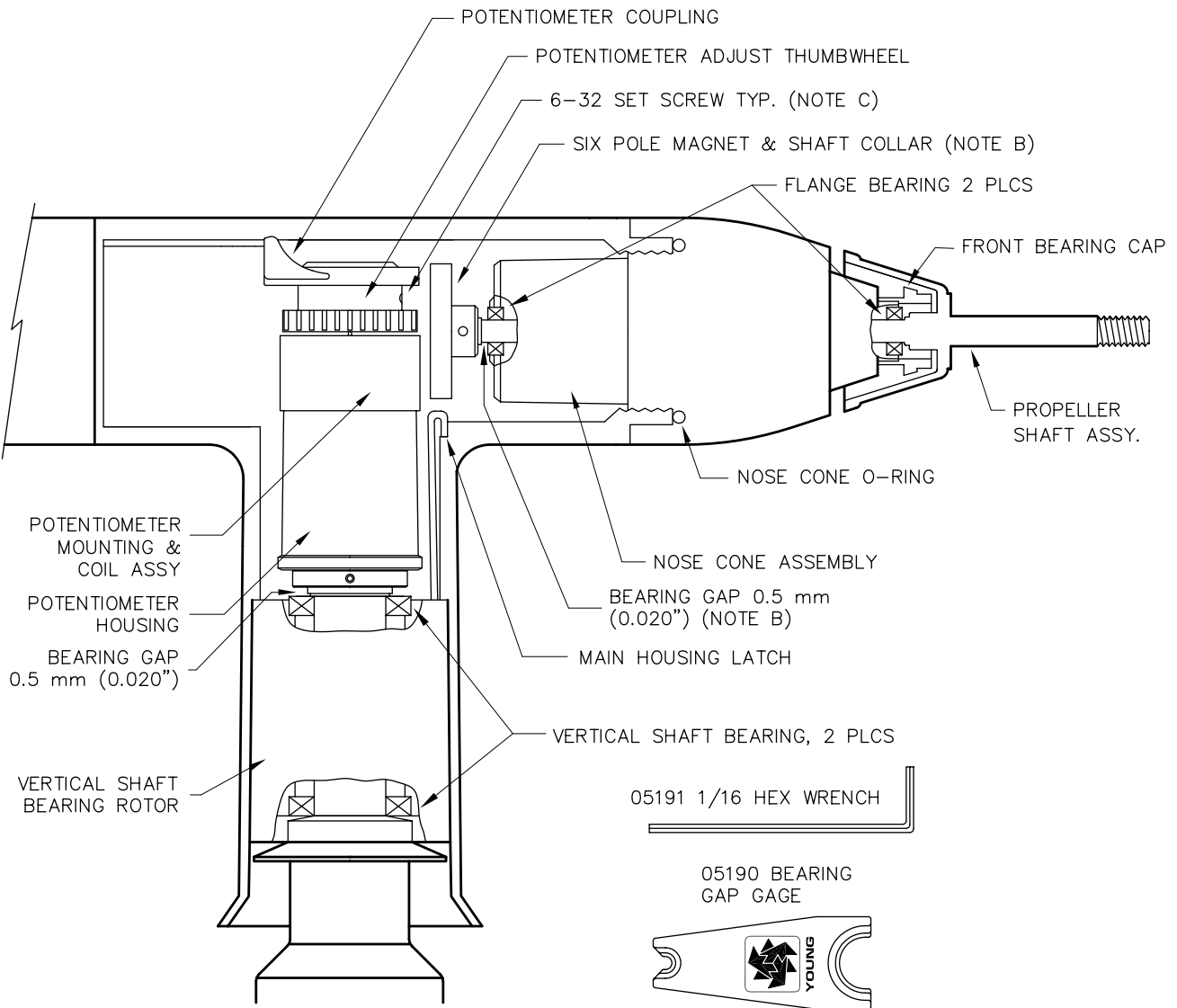

### NOTES:

- A. TO REMOVE HOUSING – UNTHREAD NOSE CONE ASSEMBLY, PUSH MAIN HOUSING LATCH, LIFT UPWARD.
- B. TO REPLACE ANEMOMETER FLANGE BEARINGS – UNTHREAD NOSE CONE, REMOVE SIX POLE MAGNET, SLIDE PROPELLER SHAFT AND HUB ASSEMBLY FORWARD, REMOVE FRONT BEARING CAP AND FLANGE BEARINGS. AFTER BEARING REPLACEMENT, SET BEARING GAP TO 0.5mm (0.020")
- C. TO ADJUST POTENTIOMETER OUTPUT SIGNAL – REMOVE NOSE CONE, LOOSEN SET SCREW IN POTENTIOMETER COUPLING, ADJUST OUTPUT SIGNAL BY MEANS OF POTENTIOMETER ADJUSTMENT THUMBWHEEL, RE-TIGHTEN SET SCREW.



# GENERAL ASSEMBLY & REPLACEMENT PARTS

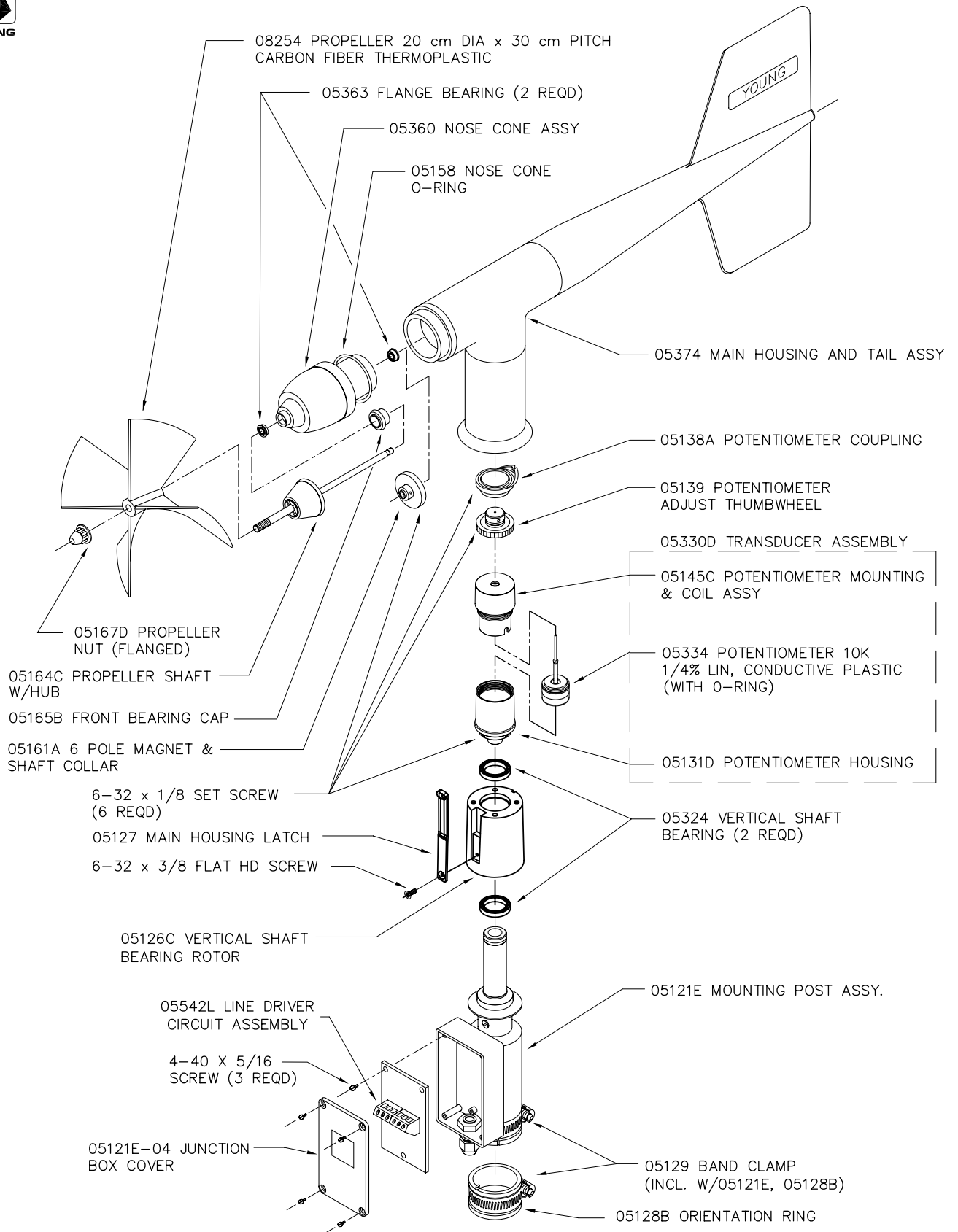





# Calibration Accessories



Model 18802  
Anemometer Drive



Model 18112  
Vane Angle Bench Stand



Model 18331 Vane Torque Gauge



Model 18310  
Propeller Torque Disc

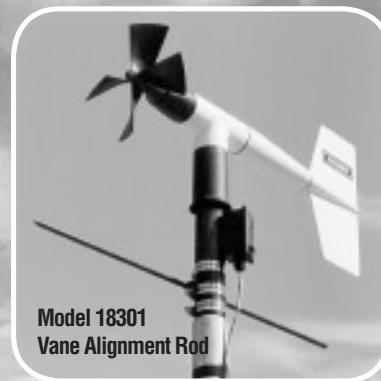

Model 18301  
Vane Alignment Rod



Model 18212  
Vane Angle Fixture-Tower Mount

**Model 18802 Anemometer Drive** provides a convenient and accurate way to rotate an anemometer shaft at a known rate. The motor may be set to rotate clockwise or counter-clockwise at any rate between 200 and 15,000 RPM in 100 RPM increments. The LCD display is referenced to an accurate and stable quartz timebase. For completely portable operation, the unit can be operated on internal batteries. For extended operation, an AC wall adapter is included.

**Model 18811 Anemometer Drive** is identical to Model 18802 except the drive motor incorporates a gear reducer for operation in the range of 20 to 990 RPM in 10 RPM increments. The lower range is recommended for cup anemometer calibration.

**Model 18112 Vane Angle Bench Stand** is used for benchtop wind direction calibration of the Wind Monitor family of sensors. The mounting post engages the direction orientation notch on the Wind Monitor. An easy to read pointer indicates 0 to 360 degrees with  $\frac{1}{2}$  degree resolution.

**Model 18212 Vane Angle Fixture - Tower Mount** similar to the Model 18112, the tower mount feature allows use on the tower as well as the bench top. The fixture is temporarily placed on the tower between the Wind Monitor and its tower mounting. Index keys and notches are engaged to preserve direction reference.

**Model 18310 Propeller Torque Disc** checks anemometer bearing torque with 0.1 gm/cm resolution. The disc temporarily replaces the propeller for torque measurement or simple yet accurate pass/fail checks. Charts included with the unit relate torque to propeller threshold with limits for acceptable bearing performance.

**Model 18312 Cup-Wheel Torque Disc** checks cup anemometer bearing torque.

**Model 18331 Vane Torque Gauge** checks vane bearing torque of the Wind Monitor family sensors. Slip the fixture over the main housing and make simple yet accurate vane torque measurements. Charts relating vane torque to vane threshold provide limits for acceptable bearing performance.

**Model 18301 Vane Alignment Rod** helps align the vane of a wind sensor to a known direction reference during installation. The base of the device has an index key that engages the direction orientation notch in the sensor allowing the sensor to be removed without losing wind direction reference.

## Specifications

### MODEL 18802 ANEMOMETER DRIVE (Replaces 18801)

**Range:**  
200 to 15,000 RPM in 100 RPM increments

**Rotation:**  
Clockwise or Counter-Clockwise

**Display Resolution:**  
1 RPM

**Quartz Timebase Reference:**  
0.1 RPM

**Power Requirement:**  
2x9 V (alkaline or lithium) batteries  
115 VAC wall adapter included  
(230 VAC – add suffix H)

### MODEL 18811 ANEMOMETER DRIVE (Replaces 18810)

**Range:**  
20 to 990 RPM in 10 RPM increments

**Display Resolution:**  
0.1 RPM

### MODEL 18112, 18212 VANE ANGLE CALIBRATION DEVICES

**Range:**  
0 to 360 degrees

**Resolution:**  
0.5 degree

### MODEL 18310, 18312 TORQUE DISC DEVICES

**Range:**  
0 to 5.4 gm-cm

**Resolution:**  
0.1 gm-cm

### MODEL 18331 VANE TORQUE GAUGE

**Range:**  
0 to 50 gm-cm

**Resolution:**  
5 gm-cm

*Specifications subject to change without notice.*

## Ordering Information

## MODEL

<b>ANEMOMETER DRIVE</b> 200 to 15,000 RPM .....	<b>18802</b>
<b>ANEMOMETER DRIVE</b> 20 TO 990 RPM .....	<b>18811</b>
<b>230V / 50-60 HZ INPUT POWER</b> .....	<b>ADD SUFFIX "H"</b>
<b>VANE ANGLE BENCH STAND</b> .....	<b>18112</b>
<b>VANE ANGLE FIXTURE - TOWER MOUNT</b> .....	<b>18212</b>
<b>PROPELLER TORQUE DISC</b> .....	<b>18310</b>
<b>CUP-WHEEL TORQUE DISC</b> .....	<b>18312</b>
<b>VANE TORQUE GAUGE</b> .....	<b>18331</b>
<b>VANE ALIGNMENT ROD</b> .....	<b>18301</b>



**R.M. YOUNG COMPANY**  
2801 Aero Park Drive  
Traverse City, Michigan 49686 USA  
TEL: (231) 946-3980 FAX: (231) 946-4772  
E-mail: met.sales@youngusa.com  
Web Site: www.youngusa.com