



GPS Module DataSheet

Name: Ultra High Sensitivity and Low Power GPS Receiver Module

Model No.: SKG10B

Revision: 01

Revision History:

Revision	Description	Approved	Date
001	Initial Release to 001		20120428

General Description

The SKG10B is a complete GPS engine module that features super sensitivity, ultra low power and small form factor. The GPS signal is applied to the antenna input of module, and a complete serial data message with position, velocity and time information is presented at the serial interface with NMEA protocol or custom protocol.

It is based on the high performance features of the MediaTek MT3339 single-chip architecture, Its -165dBm tracking sensitivity extends positioning coverage into place like urban canyons and dense foliage environment where the GPS was not possible before. The small form factor and low power consumption make the module easy to integrate into portable device like PNDs, mobile phones, cameras and vehicle navigation systems.

Applications

- LBS (Location Based Service)
- PND (Portable Navigation Device)
- Vehicle navigation system
- Mobile phone



Figure 1: SKG10B Top View

Features

- Ultra high sensitivity: -165dBm
- Extremely fast TTFF at low signal level
- Built in high gain LNA
- Low power consumption: Typical 22mA@3.3V
- NMEA-0183 compliant protocol or custom protocol
- Operating voltage: 3.0V to 4.2V
- Operating temperature range: -40 to 85°C
- SMD type with stamp holes
- Small form factor: 11.5x13x2.2mm
- RoHS compliant (Lead-free)

Pin Assignment

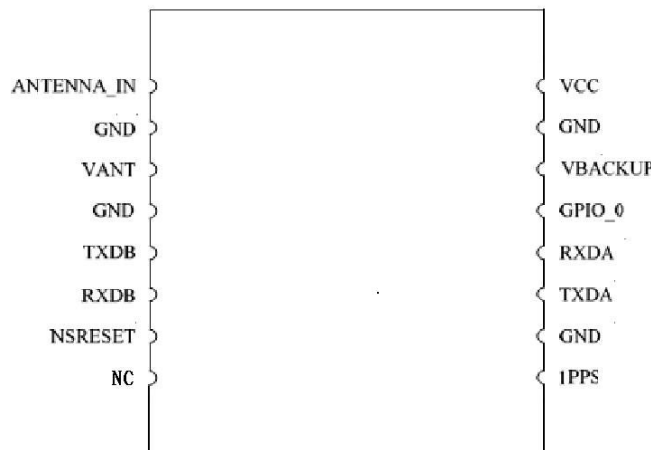

Figure 2: SKG10B Pin Package

Pin Description

Pin No.	Pin name	I/O	Description
1	ANTENNA_IN	I	Antenna Input
2	GND	G	Ground
3	VANT	I	Active Antenna External Voltage Input
4	GND	G	Ground
5	TXDB	O	Serial Data Output B
6	RXDB	I	Serial Data Input B
7	RESET	I	Module Reset (Active Low)
8	NC		No Connect
9	PPS	O	Time pulse Signal(Default 100ms pulse once per second)
10	GND	G	Ground
11	TXDA	I	Serial Data Output A
12	RXDA	O	Serial Data Input A
13	GPIO_0	I/O	General purpose I/O
14	VBACKUP	I	Ground
15	GND	G	Ground
16	VCC	I	Module Power Supply

Interfaces Configuration

Power Supply

Regulated power for the SKG10B is required. The input voltage Vcc should be 3.0V to 4.2V range, current is no less than 100mA. Suitable decoupling must be provided by external decoupling circuitry (10uF and 1uF). It can reduce the Noise from power supply and increase power stability.

Main power supply Vcc current varies according to the processor load and satellite acquisition. Maximum Vcc peak current is about 30 mA during acquisition.

Backup Battery Power

In case of a power failure on pin Vcc, real-time clock and backup RAM are supplied through pin VBACKUP. This enables the SKG10B GPS Receiver to recover from power failure with either a hot start or a warm start (depending on the duration of Vcc outage). If no Backup Battery is connected, the receiver performs a cold start upon powered up, and still need to add a bypassing capacitor (1uF) to VBACKUP pin, then can reduce noise and increase the stability.

Backup Battery Power VBACKUP draws typically 7 uA current in backup state.

RESET

The SKG10B modules include a RESET pin. Driving RESET low activates a hardware reset of the system. RESET is only an input and will not reset external circuitry. At power down the reset is forced when the Vcc drops below 2.7V.

NOTE

If not used, leave RESET not connected (floating).

Antenna

The SKG10B GPS receiver is designed for supporting the active antenna or passive antenna connected with pin ANTENNA_IN. The gain of active antenna should be no more than 25dB (18~20dB Typical). The maximum noise figure should be no more than 1.5dB and output impedance is at 50 Ohm.

NOTE

With passive antenna keep the cable loss at minimum (<1dB).

VANT

Antenna power input pin. When user wants to use external antenna, this is the antenna power input.

UART Ports

The module supports one full duplex serial channels UART. The serial connections are at 2.85V LVTTTL logic levels, if need different voltage levels, use appropriate level shifters. the data format is however fixed: X, N, 8, 1, i.e. X baud rate, no parity, eight data bits and one stop bit, no other data formats are supported, LSB is sent first. The modules default baud rate is set up 9600bps. The RXDA & TXDA recommended to pull up (10KΩ). It can increase the stability of serial data.

ANTENNA_IN

The transmission line must to be control impedance from ANTENNA_IN pin to the antenna or antenna connector of your choice. (Impedance 50Ω)

Performance Specification

Parameter	Specification
Receiver Type	L1 frequency band, C/A code, 22 Tracking / 66 Acquisition-Channel
Sensitivity	Tracking -165dBm Typical Acquisition -148dBm Typical
Accuracy	Position 3.0m CEP50 without SA(Typical Open Sky) Velocity 0.1m/s without SA Timing (PPS) 10ns RMS
Acquisition Time	Cold Start 23s(Typical Open Sky) Warm Start 23s Hot Start 1s Re-Acquisition <1s
Assisted GPS support	EPO
Power Consumption	Tracking 22mA @3.3V Typical Acquisition 27mA @3.3V
Navigation Data Update Rate	Max 10Hz Default 1Hz

Operational Limits	Altitude	Max 18,000m
	Velocity	Max 515m/s
	Acceleration	Less than 4g

Electrical Characteristics

Absolute Maximum Rating

Parameter	Symbol	Min	Max	Units
Power Supply				
Power Supply Volt.	VCC	-0.3	4.3	V
Input Pins				
Input voltage on any input connection	VIO	-0.3	3.6	V
Backup Battery	VBACKUP	-0.3	4.3	V
RF input power	ANTENNA_IN		10	dBm
Human Body Model ESD capability	ANTENNA_IN		2000	V
Machine Model ESD capability	ANTENNA_IN		100	V
Environment				
Storage Temperature	Tstg	-40	125	°C
Peak Reflow Soldering Temperature <10s	Tpeak		260	°C
Humidity			95	%

Note: Absolute maximum ratings are stress ratings only, and functional operation at the maxims is not guaranteed. Stress beyond the limits specified in this table may affect device reliability or cause permanent damage to the device. For functional operating conditions, refer to the operating conditions tables as follow.

The SKG10B module is Electrostatic Sensitive Device (ESD) and may be damaged with ESD or spike voltage. Although it has built-in ESD protection circuitry at digital I/O, please handle with care to avoid permanent malfunction or performance degradation. Note that RFIN has no ESD protection circuits.

Operating Conditions

Parameter	Symbol	Condition	Min	Typ	Max	Units
Power supply voltage	Vcc		3	3.3	4.2	V
Backup Battery	VBACKUP		2	3.3	4.2	V
Power supply voltage ripple	Vcc_PP	Vcc=3.3V			30	mV
Supply current, navigation	Icc	Vcc=3.3V		22	28	mA
Supply current, backup state	Ibckp	Vcc=3.3V		7		uA
VANT Antenna bias supply	VANT	I _{ANT} = 18 mA		3		V

Input high voltage	V_{IH}		2		3.6	V
Input low voltage	V_{IL}		-0.3		0.8	V
Output high voltage	V_{OH}		2.4		3.1	V
Output low voltage	V_{OL}		-0.3		0.4	V
Operating temperature	T_{opr}		-40		85	°C

Mechanical Specification

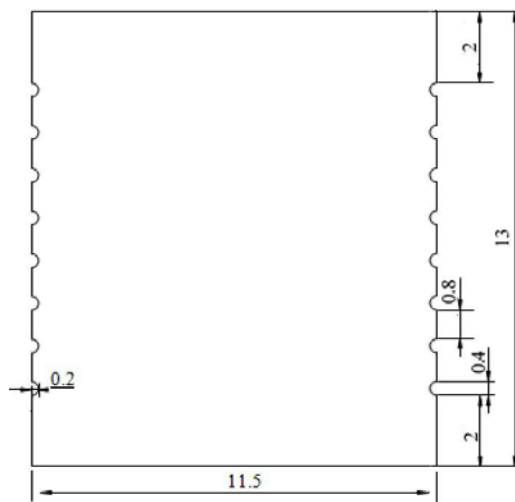

Figure 3: SKG10B Dimensions

Recommend Layout

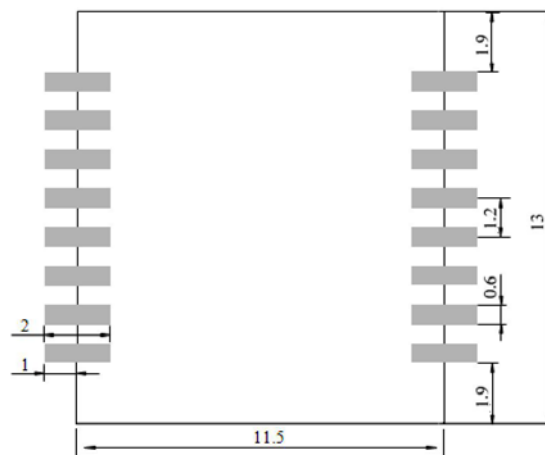
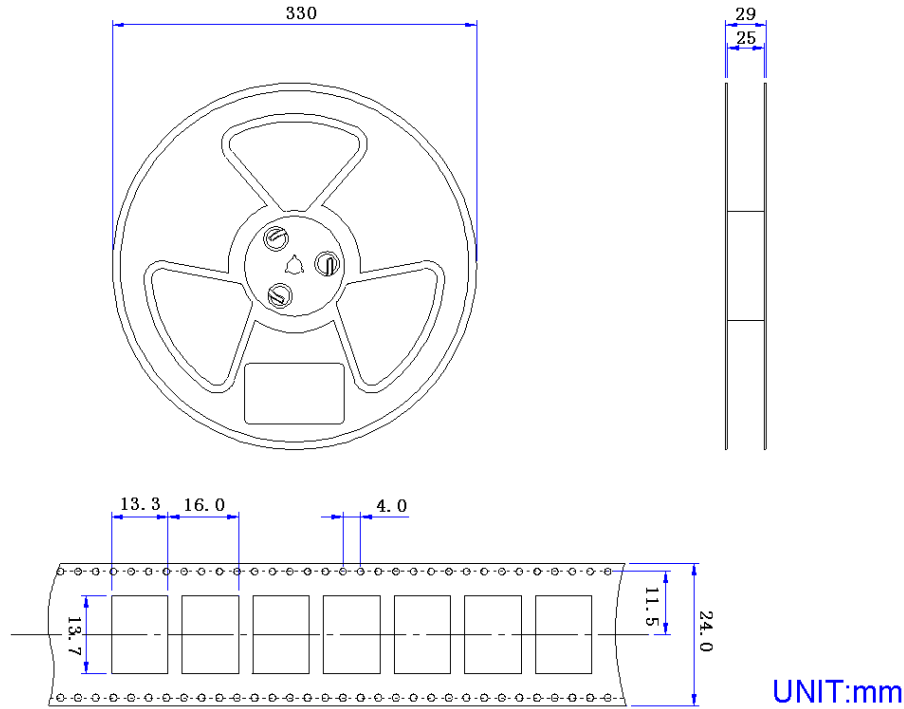

Figure 4: SKG10B Footprint

Packaging Specification

SKG10B modules are shipped in reel and with 1500 units per reel. Each tray is ‘dry’ package.



UNIT:mm

Figure 5: SKG10B Packaging

Manufacturing Process Recommendations

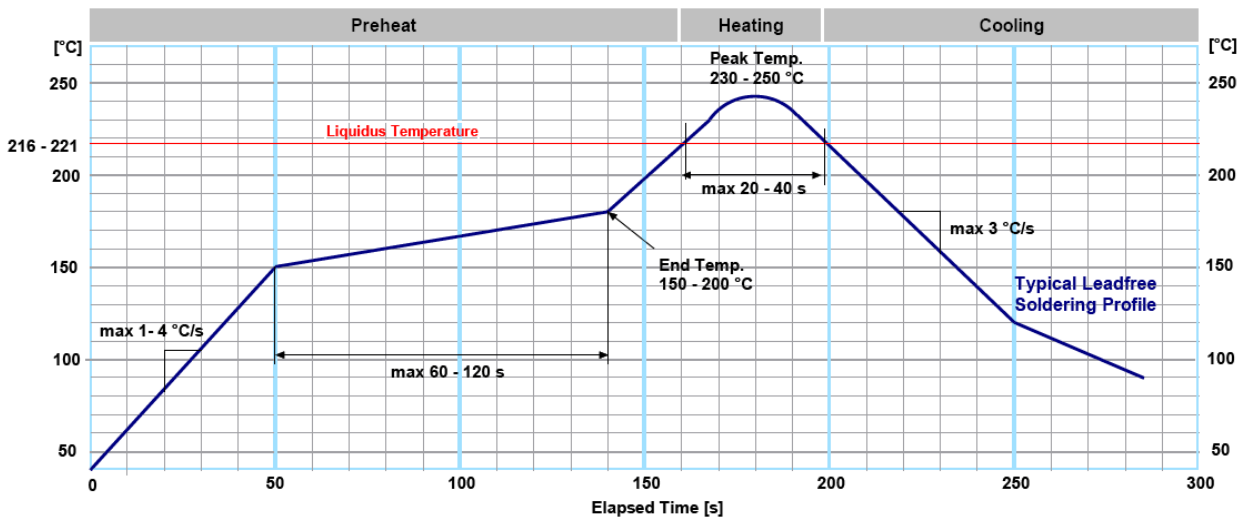

Figure 6: SKG10B Typical Leadfree Soldering Profile

Note: The final soldering temperature chosen at the factory depends on additional external factors like choice of soldering paste, size, thickness and properties of the baseboard, etc. Exceeding the maximum soldering temperature in the recommended soldering profile may permanently damage the module.

Reference design schematic

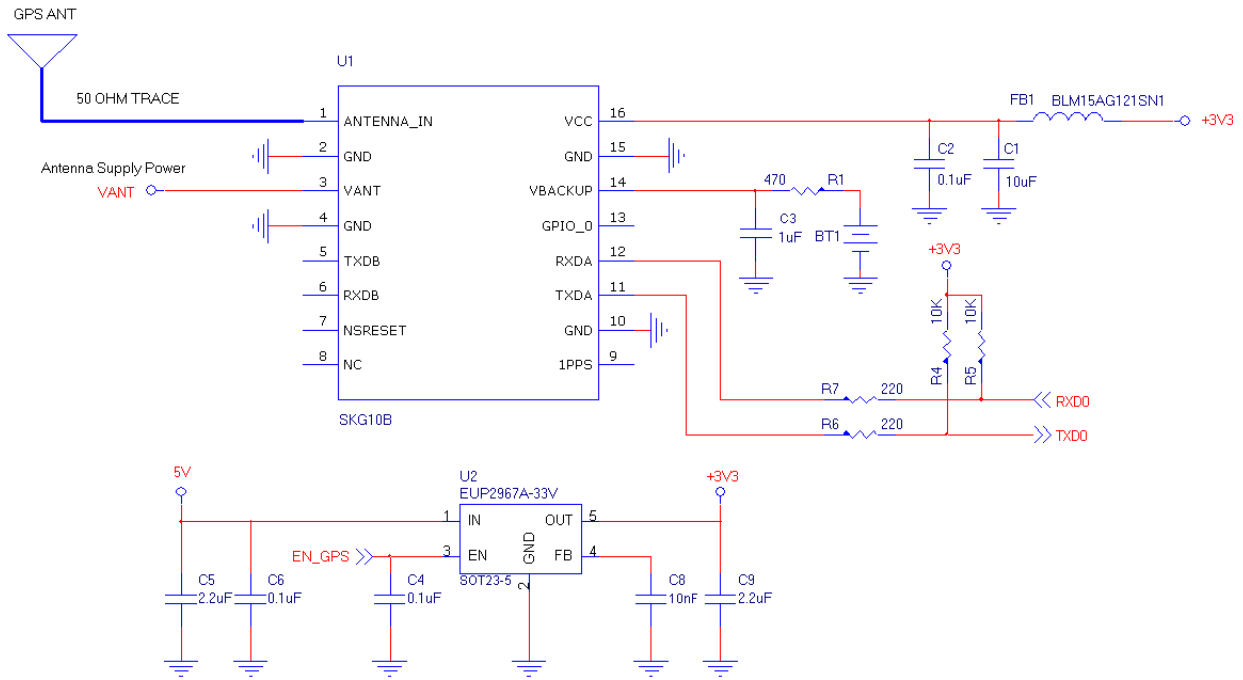

Figure 7: SKG10B Typical Reference design schematic

Software Protocol

NMEA 0183 Protocol

The NMEA protocol is an ASCII-based protocol, Records start with a \$ and with carriage return/line feed. GPS specific messages all start with \$GPxxx where xxx is a three-letter identifier of the message data that follows. NMEA messages have a checksum, which allows detection of corrupted data transfers.

The Skylab SKG10B supports the following NMEA-0183 messages: GGA, GLL, GSA, GSV, RMC, VTG, ZDA. The module default NMEA-0183 output is set up GGA, GSA, RMC, GSV, and default baud rate is set up 9600bps.

Table 1: NMEA-0183 Output Messages

NMEA Record	Description	Default
GGA	Global positioning system fixed data	Y
GLL	Geographic position—latitude/longitude	N
GSA	GNSS DOP and active satellites	Y
GSV	GNSS satellites in view	Y
RMC	Recommended minimum specific GNSS data	Y
VTG	Course over ground and ground speed	N
ZDA	Date and Time	N

GGA-Global Positioning System Fixed Data

This sentence contains the position, time and quality of the navigation fix.

See RMC for Fix Status, Fix Mode, Fix Date, Speed, and True Course.

See GSA for Fix Type, PDOP, and VDOP.

\$GPGGA,021514.000,2232.1799,N,11401.1823,E,1,6,1.25,84.0,M,-2.2,M,,*74

Table 2: GGA Data Format

Name	Example	Units	Description
Message ID	\$GPGGA		GGA protocol header
UTC Position	021514.000		hhmmss.sss
Latitude	2232.1799		ddmm.mmmm
N/S indicator	N		N=north or S=south
Longitude	11401.1823		dddmm.mmmm
E/W Indicator	E		E=east or W=west
Position Fix Indicator	1		See Table 2-1
Satellites Used	6		Range 0 to 12
HDOP	1.25		Horizontal Dilution of Precision
MSL Altitude	84.0	meters	Altitude (referenced to the Ellipsoid)
AltUnit	M	meters	Altitude Unit
GeoSep	-2.2	meters	Geoidal Separation
GeoSepUnit	M	meters	Geoidal Separation Unit
Age of Diff.Corr.	<Null>	second	Null fields when it is not Used
Diff.Ref.Station ID	<Null>		Null fields when it is not Used
Checksum	*74		
EOL	<CR> <LF>		End of message termination

Table 2-1: Position Fix Indicators

Value	Description
0	Fix not available or invalid
1	GPS SPS Mode, fix valid
2	Differential GPS, SPS Mode, fix valid
3	GPS PPS Mode, fix valid

GLL-Geographic Position – Latitude/Longitude

This sentence contains the fix latitude and longitude.

\$GPGLL,2232.1799,N,11401.1824,E,021513.000,A,A*50

Table 3: GLL Data Format

Name	Example	Units	Description
Message ID	\$GPGLL		GLL protocol header
Latitude	2232.1799		ddmm.mmmm
N/S Indicator	N		N=north or S=south
Longitude	11401.1824		dddmm.mmmm

E/W Indicator	E		E=east or W=west
UTC Position	021513.000		hhmmss.sss
Fix Status	A		A=data valid or V=data not valid
Fix Mode	A		A=autonomous, N = No fix, D=DGPS, E=DR
Checksum	*50		
EOL	<CR> <LF>		End of message termination

GSA-GNSS DOP and Active Satellites

This sentence contains the mode of operation, type of fix, PRNs of the satellites used in the solution as well as PDOP, HDOP and VDOP.

\$GPGSA,A,3,26,05,18,15,27,29,,,,,,1.52,1.25,0.87*0F

Table 4: GSA Data Format

Name	Example	Units	Description
Message	\$GPGSA		GSA protocol header
Mode 1	A		See Table 4-2
Mode 2	3		See Table 4-1
ID of satellite used	26		Sv on Channel 1
ID of satellite used	05		Sv on Channel 2
...
ID of satellite used	<Null>		Sv on Channel 12 (Null fields when it is not Used)
PDOP	1.52		Position Dilution of Precision
HDOP	1.25		Horizontal Dilution of Precision
VDOP	0.87		Vertical Dilution of Precision
Checksum	*0F		
EOL	<CR> <LF>		End of message termination

Table 4-1: Mode 1

Value	Description
1	Fix not available
2	2D Fix
3	3D Fix

Table 4-2: Mode 2

Value	Description
M	Manual-forced to operate in 2D or 3D mode
A	Automatic-allowed to automatically switch 2D/3D

GSV-GNSS Satellites in View

This sentence contains the PRNs, azimuth, elevation, and signal strength of all satellites in view.

\$GPGSV,3,1,12,15,79,333,42,42,50,127,,29,45,263,44,02,36,124,30*7E

\$GPGSV,3,2,12,26,36,226,34,05,35,046,22,27,33,161,29,21,16,319,*7D

\$GPGSV,3,3,12,10,15,066,31,18,14,285,45,24,12,319,15,08,09,047,18*7E

Table 5: GSV Data Format

Name	Example	Units	Description
Message ID	\$GPGSV		GSV protocol header
Number of Message	3		Total number of GSV sentences (Range 1 to 3)
Message Number	1		Sentence number of the total (Range 1 to 3)
Satellites in View	12		Number of satellites in view
Satellite ID	15		Channel 1(Range 01 to 32)
Elevation	79	degrees	Channel 1(Range 00 to 90)
Azimuth	333	degrees	Channel 1(Range 000 to 359)
SNR(C/NO)	42	dB-Hz	Channel 1(Range 00 to 99, null when not tracking)
...			...
Satellite ID	02		Channel 4(Range 01 to 32)
Elevation	36	degrees	Channel 4(Range 00 to 90)
Azimuth	124	degrees	Channel 4(Range 000 to 359)
SNR(C/NO)	30	dB-Hz	Channel 4(Range 00 to 99, null when not tracking)
Checksum	*7E		
EOL	<CR> <LF>		End of message termination

Depending on the number of satellites tracked multiple messages of GSV data may be required.

RMC-Recommended Minimum Specific GNSS Data

This sentence contains the recommended minimum fix information.

See GGA for Fix Quality, Sats Used, HDOP, Altitude, Geoidal Separation, and DGPS data.

See GSA for Fix Type, PDOP and VDOP.

\$GPRMC,023345.000,A,2232.1767,N,11401.1953,E,0.18,151.55,100410,,A*6B

Table 6: RMC Data Format

Name	Example	Units	Description
Message ID	\$GPRMC		RMC protocol header
UTS Position	023345.000		hhmmss.sss
Status	A		A=data valid or V=data not valid
Latitude	2232.1767		ddmm.mmmm
N/S Indicator	N		N=north or S=south
Longitude	11401.1953		dddmm.mmmm
E/W Indicator	E		E=east or W=west
Speed Over Ground	0.18	Knots	
Course Over Ground	151.55	Degrees	True Course
Date(UTC)	100410		ddmmyy
Magnetic variation	<Null>	Degrees	Null fields when it is not Used
Magnetic Variation Direction	<Null>		E=east or W=west (Null fields when it is not Used)
Fix Mode	A		A=autonomous, N = No fix, D=DGPS, E=DR
Checksum	*6B		

EOL	<CR> <LF>		End of message termination
-----	-----------	--	----------------------------

VTG-Course Over Ground and Ground Speed

This sentence contains the course and speed of the navigation solution.

\$GPVTG,148.81,T,,M,0.13,N,0.24,K,A*3D

Table 7: VTG Data Format

Name	Example	Units	Description
Message ID	\$GPVTG		VTG protocol header
Tcourse	148.81	Degrees	True Course
Reference	T		T = True
Mcourse	<Null>	Degrees	Magnetic Course (Null fields when it is not Used)
Reference	M		M = Magnetic (Null fields when it is not Used)
Speed over ground	0.13	Knots	Nautical Miles per Hour
Units	N		Knots
Speed over ground	0.24	Km/hr	in Kilometers per Hour
Units	K		Kilometer per hour
Mode	A		A=Autonomous, N=No fix, D=DGPS, E=DR
Checksum	*3D		
EOL	<CR> <LF>		End of message termination

ZDA-Date and Time

This sentence contains UTC date & time, and local time zone offset information.

\$GPZDA,023345.000,10,04,2010,,*50

Table 8: ZDA Data Format

Name	Example	Units	Description
Message ID	\$GPZDA		ZDA protocol header
UTC Time	023345.000		hhmmss.sss
Day	10		UTC time: day (01 ... 31) dd
Month	04		UTC time: month (01 ... 12) mm
Year	2010		UTC time: year (4 digit year) yyyy
local zone hours	<null>		Local Time Zone Offset Hours (Null fields when it is not Used)
local zone minutes	<null>		Local Time Zone Offset Minutes (Null fields when it is not Used)
Checksum	*50		
EOL	<CR> <LF>		End of message termination

Skylab M&C Technology Co., Ltd.

Address: Room.801, Bldg.211, Terra Industrial Park, Futian District, Shenzhen

Phone: 86-755 8340 8210 (Sales Support)

Phone: 86-755 8340 8130 (Technical Support)

Fax: 86-755-8340 8560

E-Mail: sales1@skylab.com.cn

Website: www.skylab.com.cn